

University of Kansas School of Engineering
High School Design Competition
2024 Rules Packet



Competition Day: **October 23, 2024**
Hosted by the University of Kansas School of Engineering

Rules Packet Version 2
Last updated: 9/17/24

Table of Contents

General Information	3
Aerospace Engineering Competition	7
Bioengineering Competition	13
Chemical Engineering Competition	18
Civil Engineering Competition	23
Computer Science Competition	27
Mechanical Engineering Competition	33

General Information

What is High School Design?

High School Design is a free event that takes place annually in the fall, putting high school students' creativity, teamwork skills, technical knowledge, and abilities to the test. Each High School Design features new engineering design challenges in various engineering disciplines created by students in the Self Engineering Leadership Fellows (SELF) Program. Working as individuals or in small teams, high school students design, build, and test a project that addresses the design criteria.

High School Design is hosted by the KU School of Engineering, while SELF fellows plan and execute the event. It is a day-long event that is student-run, with the intent of promoting interest in engineering amongst high school students.

General Rules

- Must be currently enrolled in at least five high school courses at an accredited high school or alternative non-traditional school at the time of competition. Students enrolled in dual credit/concurrent enrollment classes earning progress towards their high school diploma and college credit are also permitted to compete.
 - If you have any questions about your eligibility, please reach out to highschooldesign@ku.edu.
- Maximum team size: 5.
- All work presented must be your own. Outside resources must be cited. Plagiarism will not be tolerated. See Code of Conduct for guidelines surrounding AI.
- All team members must be registered before the competition, providing all required information and documentation (all explained on the registration form).
- All teams competing in the High School Design competition must complete registration by Monday, OCTOBER 7th.
- All project work must be submitted in the timeframe specified by the specific competition rules.
- Team name: Each team must have an appropriate name that is not offensive or discriminatory.
- Teams are required to have a teacher, mentor, parent or legal guardian who serves as an advisor/coach for the team, and it is expected that they are present throughout the duration of the competition.
- Each participant is only allowed to compete in 1 competition and on one team.
- **Teams will compete in person at the University of Kansas School of Engineering on October 23rd 2024**

Scholarship Details

For each of the six competitions (Aerospace, Bioengineering, Chemical, Civil, Computer Science, Mechanical), the winning team will receive a \$2,000 University of Kansas scholarship. This scholarship will be divided equally among all winning team members equally. Only the first-place team will be eligible for the scholarship in each of the six competitions and the scholarship is not transferrable. Scholarships will be contingent on student(s) enrolling in any school at the University of Kansas and is not limited to enrollment in the School of Engineering. The scholarship is awarded over the first two semesters at KU, 50% in the fall and 50% in the spring. Only the first-place team members will be eligible for the scholarship in each of the six competitions and the scholarship is non-transferrable.

Immediately following conclusion of the competition, all first, second, and third-place teams will be announced. While we hope that all teams stay for the closing ceremony, the team does not have to be present to accept their scholarship award.

Scholarship eligibility:

- Scholarship recipients must meet all the of the general rules
- Students whose parents or legal guardians are employed by the University of Kansas School of Engineering are encouraged to participate if they meet all the requirements of the general rule but are not eligible to be awarded the scholarship. In the event that a member of the first place team is ineligible because of this, the award will be distributed equally among the remaining members of the team. If no one on the first place team is eligible, the scholarship will be awarded to the second place team.

HSD Code of Conduct

Each team member and mentor must agree to abide by the code of conduct.

1. Respectful behavior: All participants must treat each other with respect and courtesy, regardless of their background, ethnicity, gender, religion, or sexual orientation.
2. Non-discrimination: All forms of discrimination, including harassment, bullying, or intimidation, are strictly prohibited.
3. Ethical conduct: All participants must uphold the highest standards of ethical conduct, including honesty, integrity, and fair play.
4. Safety: All participants must follow the safety guidelines established by the competition organizers, including wearing appropriate protective gear and following safe practices when working with tools or equipment.
5. Intellectual property: All participants must respect intellectual property rights, including copyrights, trademarks, patents, and trade secrets; participants must not engage in any form of plagiarism or misappropriation of others' work. This includes the use of AI tools such as ChatGPT, Microsoft Copilot, etc.

6. Professionalism: All participants must behave professionally, including being punctual, prepared, and attentive during all competition events.
7. Sportsmanship: All participants must exhibit good sportsmanship, including accepting the results of the competition with grace and respecting the judges' decisions. Detailed feedback for all teams will be provided.
8. Compliance: All participants must comply with the competition rules and guidelines, as well as any applicable laws and regulations.
9. Consequences: Any violation of this code of conduct may result in disqualification and dismissal from the competition.
10. Tardiness: All participants must be on time for all scheduled activities to the best of their ability. Competition leads may or may not be able to accommodate late teams.

Important Dates

Registration Opens	May 2, 2024
Registration Closes	October 7, 2024
Competition Day	October 23, 2024

Accommodations

If any students require accommodation to participate, we are dedicated to giving them an equal opportunity to engage in the competition, please reach out to highschooldesign@ku.edu and we will work with you to accommodate your students!

Competition Rules

The remainder of this packet will include the detailed rules of each of the six competitions. Each student may participate in only one competition. Students may be in teams of 1-5 and each school may enter as many teams as they please. As such, please fill out the team registration survey and liability forms listed on the website!

Questions Regarding Competition Rules

If students or advisors have questions regarding the competition rules, they may reach out to their respective competition's representative (listed in their corresponding section of rules) and cc highschooldesign@ku.edu. Please be patient as our competition is run by full-time students, so if you do not hear back within 3 days, please send a follow-up email.

Competition Leads

- Aerospace: Haley Pfeifer (haley.pfeifer@ku.edu) and Lauren Brinsfield (lbrinsfield@ku.edu)
- Bioengineering: Steven Young (s463y758@ku.edu), Ryan Dahl (r509d016@ku.edu) and Joel Adejola (jadejola@ku.edu)
- Civil: Mac Key (mac.key@ku.edu) and Kelsey Schnettgoecke (kelseyschnettgoecke@ku.edu)

- Chemical: Irene Xu (irene.xu@ku.edu) and Zion Bradsher (zion@ku.edu)
- Computer Science: Dylan Kneidel (dckneidel@ku.edu) and Srihari Meyoor (smmeyoor@ku.edu)
- Mechanical: Claire Thompson (claire.thompson@ku.edu) and Audrey Irmischer (irmischeram@ku.edu)

High School Design: *Aerospace Competition*

With support from



Competition Overview

In a natural disaster, emergency supplies sometimes must be brought in by plane. In a rural disaster, the runways can be short, and landing the plane close to the target zone is very important. In this competition, teams are tasked with designing a glider capable of landing and coming to a complete stop near the target landing zone.

The glider will launch by sliding off a ramp positioned above the ground so that the initial force applied to all gliders is equal. Overall, the competition will consist of three flight tests and a 3–5-minute presentation that will cover your design plan, costs, challenges you faced along the way, how you overcame them, and why your glider is the best choice for customers. A panel of aerospace industry representatives and aerospace engineering students will be present for the flight tests and the presentation. Details of each part of the competition are given below.

Flight Testing

This category measures the glider's distance from its landing spot to the target destination. The target will be 42 feet horizontally and approximately 17 feet vertically from the launch site. The key to this section is to find a balance between the glider's horizontal and vertical velocity with the optimal glide path angle. The Competition Procedure section below provides more details of the flight-testing procedure.

Prior to the competition, students will receive their schedule for competition day. This will detail the order and time each team will fly.

1. Before each team's first flight test, School of Engineering representatives will conduct a technical inspection to ensure the team's glider meets vehicle specifications. If the team makes any significant repairs between flights, the glider will need to be inspected again before the next flight to ensure continued compliance. If the glider does not meet specifications, the team forfeits that flight

test as detailed above. The team will have the chance to fix the glider to meet specifications before each flight attempt. If the team fails to pass tech inspection during all three flight attempts, they receive a zero for the flight score, but may still participate in presentation.

2. In each flight test, teams will each be allowed one successful launch attempt. All launches are considered successful except if:
 - a) A vehicle collides with any other objects while in the air.Or
 - b) A glider gets stuck to the ramp and does not touch the ground.
3. The distance will be measured from the middle of a 10-inch diameter circle to the nearest point on the glider when it comes to a complete stop (via the shortest distance from plane to target). The circle only acts as a visual aid; it does not represent scoring. See scoring below.

If a launch is deemed unsuccessful, the team will have one chance to redo that test. This is the only case in which a redo will be allowed.

Students will have time to repair any damage done to their vehicle between their two flight tests, but not between tests in the case of an unsuccessful launch. The repairs must not alter the original design of the vehicle, only repair damages sustained within the competition.

Participants must not interfere with the launching or landing of their glider or the measuring process. Failure to abide by these rules will result in a disqualification.

Presentation

The presentations will also have a given rotation order that will prevent conflict with your flight time. Your team will give this presentation to a group of industry professionals and University of Kansas representatives. In engineering, it is important to be able to effectively communicate your designs, their purposes, and why your design is the best option on the market.

The presentation must include:

1. Names of all team members and team name.
2. An explanation of a prototyping process and/or design process. How does your glider meet the needs of a precise landing in an emergency?
 - a. This may include a drawing of a projected design or a few prototype gliders.
3. A list of all materials used, including itemized unit cost and total cost. If you are using items you already have, provide your best current market cost estimate.
4. Challenges your team faced and how you overcame them.
5. An explanation of why the team chose their final design and why it is the best on the market, including dimensions of the final glider.

Competitors are encouraged to lean into the theme of the product pitch. Although it will not be part of your presentation score, coming up with a company name or designing a logo for your product is a fun way to feel more immersed in the experience! Remember, you are an engineer pitching their product to a potential client. Feel free to get in the spirit of the presentation!

Students are welcome to add additional information about their glider if the presentation remains within the 3–5-minute window and is relevant to the competition.

The students will bring their posters or submit their presentations by email to haley.pfeifer@ku.edu the day before the competition with the subject line

HSD_YourTeamName_Presentation. This is to ensure your presentation can be found and efficiently presented to the judges. The students will be given 3-5 minutes to present, and judges will make notes and ask questions after the student has completed. The judges will pull questions from a list of pre-determined topics, curated by the aerospace competition team prior to event day.

Rules

Specifications for Vehicle

The vehicle must be easily identifiable as a glider as defined [here](#) by NASA, contain wings, and must demonstrate an ability to sustain glider flight. Vehicles without lifting surfaces are not allowed (i.e. baseballs, lawn darts, frisbees, etc.)

The vehicle should be of the team's own design. Kit pieces may be used for any part of the glider that is not the fuselage (main body) or primary lifting surface (wing or similar lifting device). The fuselage and primary lifting surface must be manufactured by the competitors. Kit designs may be used for inspiration. The vehicle must be designed and built primarily by the competitors. Outside help may be used, but competitors are expected to be familiar with their vehicle. Some guidance from individuals other than the team competitors is allowed, but competitors must be able to explain all rationale and procedures associated with construction.

The vehicle must be able to generate lift with no external assistance. The vehicle will be placed on a ramp (see description below for specifications) and released from a standstill by a School of Engineering representative. The glider should be able to slide off the ramp without pushing or nudging. Wheels are allowed.

The vehicle must have no external power source. This includes rubber bands, electric motors, and propellers.

The vehicle should not pose any safety risks to any people or property at the competition. This means that sharp edges, dangerous chemicals, and heavy materials are all prohibited.

The test will take place in a gym. Competitors should take care not to damage the gym floor. The vehicle should not leave any dents or marks on the floor upon landing.

The vehicle must have a wingspan of less than 2.5 ft., a fuselage length of less than 2 ft., and a height of less than 6 in. This is to ensure the vehicle can be transported to the upper level of the competition area for launch.

Paper airplanes are not allowed. Competitors may use paper in their design, but the final product should be more than just a folded piece of paper.

The vehicle should not weigh more than 5 lbs.

The vehicle should not purposely change shape during flight (i.e. parachutes or variable wing shapes).

The judges and competition coordinators reserve the right to disqualify a vehicle if they deem it to violate any of the above rules, if it violates the spirit of the competition, or if the competitors behave in an unprofessional manner.

Diagrams/Schematics

Specifications of Release Ramp:

Gliders will be released down a 25-degree ramp which can be seen below. This ramp is positioned so the lowest point is approximately 17.3 feet off the ground. In addition, staff

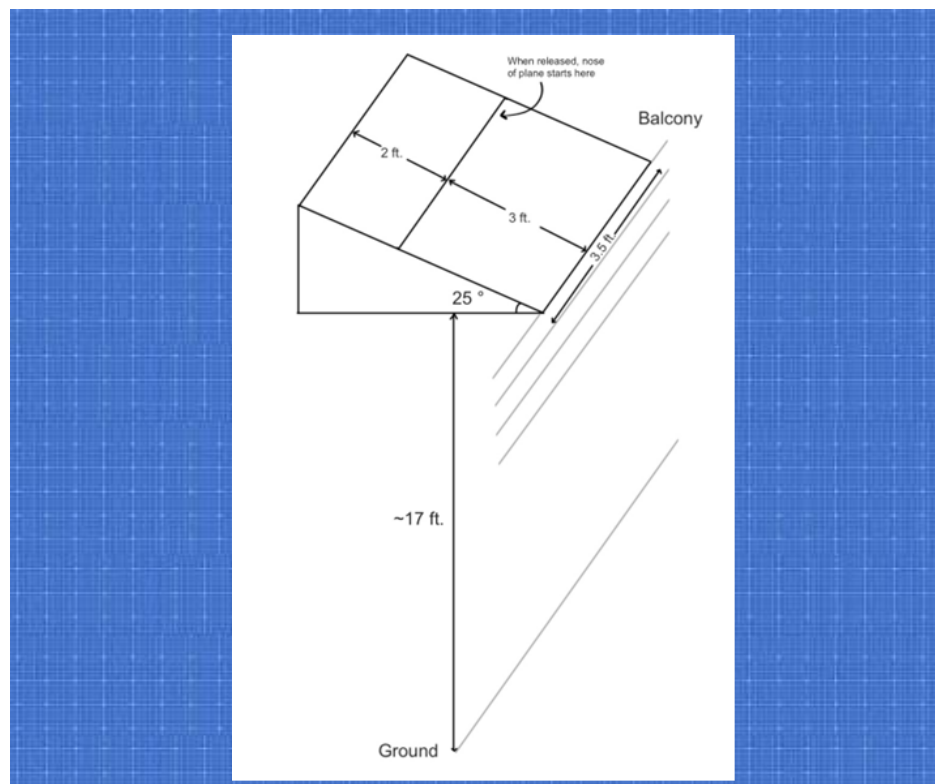

and volunteers will be the “launch technicians.” Students will not be releasing their own gliders to ensure launch consistency across teams. The launch technicians will simply release the glider down the ramp. The gliders must fit on the ramp without any special modifications. The ramp will be covered in a smooth cardboard finish. Students should design their planes to easily move down the ramp. The aerospace competition team is not responsible if a plane cannot make it down the ramp due to friction.

Scoring

Flight Testing: 30% each, 90% total.

Each flight will be worth 30% of your total score. The flight-testing scores are measured from the destination target to the closest part of the glider once it comes to a complete stop. Scores are calculated as follows:

Awarded Points Formula for Each Flight:

$$Score = \frac{30}{\frac{x}{10} + 1}$$

with the distance from the target (x) in feet, rounded down to the nearest 3-inch increment (ex. 32 inches = 2 feet 8 inches, rounded down to 2 feet 6 inches, becomes 2.5 feet). This means that if the glider is directly on the target, competitors will be awarded the maximum score of 30 points for that flight. A distance of 10 feet from the target will earn the competitors 15 points for that flight. (If you want to see how the distance from the target affects the score, you can use this [Desmos graph](#) and test different distance values.)

Presentation: 10%

The scoring categories for the presentation include content, organization, professionalism, and question response. The descriptions for each category are as follows:

Content: The presentation must include information about your design process for creating your glider, the materials, cost, and labor for creating your design, why your glider is the best choice for judges, and any other information about your preparations for the competition. We want to know what you have learned and will take away from this event.

Organization: This includes the visual aid. Your presentation and all visual aids should be concise and purposeful.

Professionalism: As an engineer, professionalism is of the utmost importance, especially when submitting designs to clients. We want you to treat the judges like professional clients. This means being respectful, friendly, and attentive. The second part of this category includes presentation skills. The judges will be looking for eye contact, proper pronunciation, and normal talking speed. We expect all team members to talk equally throughout the entire presentation.

Question Response: The judges will ask questions at the end of each presentation. These questions will be used to clarify any ambiguous ideas, test your ability to interpret the results of the flight tests, and enquire into how you might approach this competition if given another chance. The judges will not be trying to trick you. They simply want to learn more about your project and what you will take away from this experience.

Scoring Categories	Not Present	Needs Much Improvement	Adequate	Proficient	Excellent
Content	0%	40%	60%	80%	100%
Organization	0%	40%	60%	80%	100%
Professionalism	0%	40%	60%	80%	100%
Question Response	0%	40%	60%	80%	100%

The final presentation score will be an average of all category percentages multiplied by 20. For example, if someone scores 60% on content, 100% on organization, 80% on professionalism, and 80% on question response, their score averages 80%. This means they receive 16 points from the presentation category.

After all the tests have been completed, the points will be added up and a winner will be declared. In the case of a tie, the team with the smallest distance in the target test will be chosen as the winner of the aerospace competition. If a tie remains, the team with the highest score in the professionalism category of the presentation will be chosen.

What To Expect Day of Competition

Your team is expected to have your vehicle complete prior to your arrival at the University of Kansas. All materials brought in will be inspected to make sure they meet the required specifications listed above. All materials that do not pass inspection will not be allowed in the competition. Items brought to repair your vehicle can be utilized between tasks but not between back-to-back launches.

A list of what materials to bring on competition day:

- Your vehicle
- Your presentation
- The total bill of materials/itemized project budget
- Any materials needed for repairs.

Contact Information

For questions regarding competition rules and specifications, please contact:
Haley Pfeifer and Lauren Brinsfield | haley.pfeifer@ku.edu | lbrinsfield@ku.edu

High School Design: **Bioengineering Competition**

With support from



Problem Statement

For first responders during emergency scenarios, it's important to first ensure personal safety. To that end, Personal Protective Equipment (PPE) such as helmets are necessary. For this event, teams will design helmets that reduce the force imparted to the head. This will have to protect from multiple impacts and be easy to wear while doing difficult work.

Background

Safety Helmets are generally tested via pneumatic droppers onto an anvil (see <https://www.ncbi.nlm.nih.gov/pmc/articles/PMC9379520/>). Though helmets frequently must meet many standards, the characteristic being tested in this High School Design Competition event is impact attenuation- the ability to reduce the maximum acceleration caused by an impact the head experiences. In this event, instead of dropping the helmet on an anvil, we will be swinging an anvil to impact the helmet (see Fig. 1). Here, the anvil will be made of wood.

Overall Design Statement

Create a helmet that reduces the acceleration of the head (Styrofoam sphere) when it experiences an impact. All teams will be tested with the same impact force. The impact will be created by an anvil made of a wood block.

Design Requirements

- Create a helmet that will fit on an 8-inch diameter Styrofoam sphere. ([This is an example of a Styrofoam sphere that meets the specification.](#))
- The helmet must weigh at most 5_lbs (more points are given for lighter designs).

- The helmet cannot exceed length-width-height dimensions of 14 inches x 14 inches x 14 inches. Helmets will need to fit into a box that verifies these dimensions.
- The helmet must cover the upper 4” hemisphere of the Styrofoam sphere (see Fig.1).
- The helmet must be marked showing the impact target point. Target point will be marked as a 1” diameter circle such that the center point of the mark is on the horizontal bisection line of the sphere when the head is angled 30 degrees down (Fig. 1).
- The helmet must be designed to provide protection from all possible angles of impact. However, in this competition, the testing will only occur via direct linear impact at the impact target location described.
- The helmet must be secured in such a way that it does not fall off after impact, and does not damage or alter the head (Styrofoam sphere)
- The helmet must allow for flush and direct impact by the anvil on the target site (i.e. not impeded by a “brim”)

Restrictions

- The helmet may not consist of any of the following materials:
 - Fiberglass
 - Carbon fiber
 - Electrical components
 - Any hazardous material (Asbestos, etc)
- The helmet must be the team's own creation. Commercially available parts or materials may be used but cannot wholly perform the same function of the team's final submission that affect the tested characteristics. For example, the shell of a bicycle or construction helmet may not be present as the whole shell of the team’s submission. However, parts of the shell could be disassembled or modified into the final submission. A chin strap or restraining mechanism would not be a part of the construction that affects the tested characteristics and could therefore be used in the final design (borderline cases will be ruled on by the judges. Generally, if you think you might be in violation of the rules, you probably are).

Detailed Testing Procedure

A human head will be modeled as an 8-inch diameter Styrofoam sphere to create a standard for all teams to design to.

Dimensions and Weight

Participants will first have the dimensions of the helmet checked and the helmet weighed.

Securing the Helmet

At their assigned testing time, teams will be given 5 minutes to secure their helmet to the testing head. The sphere will be oriented downward such that the entirety of the pendulum impact will be on the helmet at the target impact point. Target point will be marked previously by the team as a 1" diameter circle such that the center point of the mark is on the horizontal bisection line of the sphere when the head is angled 30 degrees down (Fig. 1). The helmet should fit snugly on the 8 inch testing head and be secured such that it does not damage the Styrofoam and does not deviate from its initial position on the head upon impact more than 1 cm from the original position on the centerline. If the helmet is displaced on the head excessively during the impact, that trial will not be valid and a retest will be allowed. If the helmet is displaced 3 times resulting in invalid trials, the helmet will be ruled ineffective and receive a score of 0 for Acceleration Score.

Acceleration Score

The helmet should be designed to withstand multiple impacts. For this competition, three impact trials will occur at the designated impact target on the front of the helmet. The designated impact point will be on the front of the helmet on the horizontal bisection line with the helmet tilted 30 degrees forward (See Fig. 2). This is so the impact occurs away from the edge of the helmet.

An accelerometer will be embedded in the back of the Styrofoam head and will measure the maximum acceleration upon impact.

The values obtained in the three trials will be averaged to produce the value for acceleration. The team with the smallest acceleration will receive the full 65 points; lesser teams will receive a fraction of 65 points (see scoring formula).

Presentation

Teams must put together a presentation describing their helmet and explain why they made certain design decisions. Presentations should be no longer than 5 minutes and will be judged on content, organization, and professionalism. Then, the teams will be given 3 minutes to respond to questions.

Scoring

Any helmet that does not meet all of the design requirements and restrictions will not be eligible for an overall score but will still be tested. We strongly encourage teams to make sure that all requirements and restrictions are met prior to the competition. If the helmet is deemed to not meet these requirements, the team will be given 2 chances to modify the helmet to meet the requirements prior to the beginning of the trial.

Category	Points
Weight	20
Acceleration Reduction	65
Presentation	15
Total	100

Weight and design requirements:

<u>Category (lbs.)</u>	<u>Points Awarded</u>
0-0.75	20
0.75-1.5	14
1.5-3	10
3-4	6
4-5	0
5+	Disqualification from Testing

Acceleration Reduction

$$65 \cdot \frac{A_m}{A_i}$$

Where A_m is the minimum average acceleration measured by any team and A_i is the average acceleration measured by the team being scored.

Presentation

Teams will have 5 minutes to present and 3 minutes to respond to questions from the judges.

Content	6
Organization	3
Professionalism	3
Response to Questions	3

Fig 1: Impact points must be marked with 1" dia. markings and line up on the horizontal bisection of the sphere when the helmet is angled 30° down. (Fig not to scale). 8" diameter head.

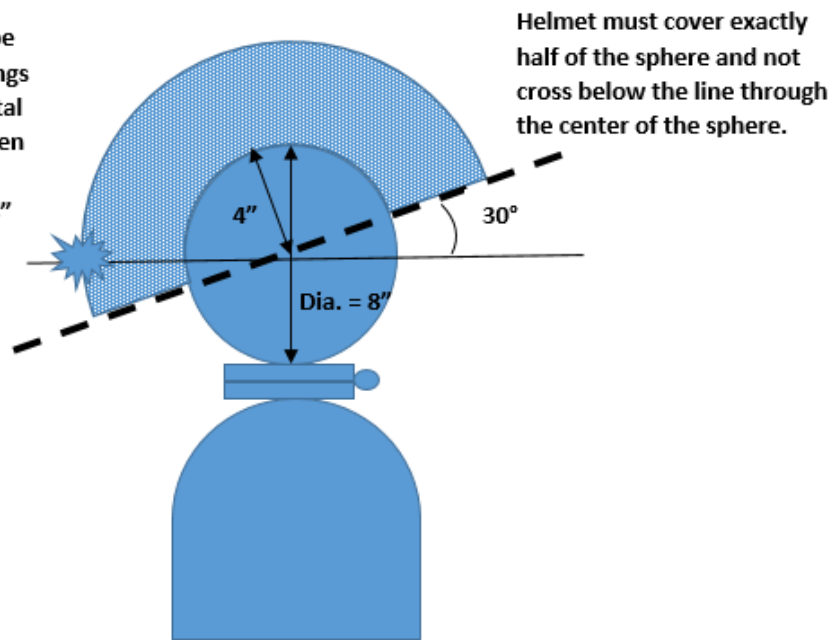

Fig 1:

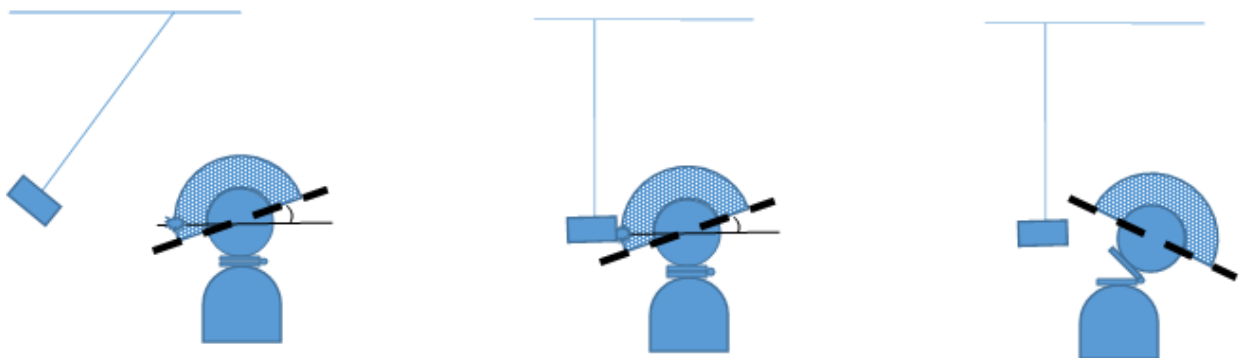

Fig 2:

High School Design: **Chemical Engineering Competition**

With support from



Competition Overview

You've been recruited to design a crucial water filter for a city grappling with the aftermath of a recent flood. This disaster has washed a significant amount of ash and soot from a nearby power plant into a lake essential for thousands of residents' drinking water.

As authorities work on broader lake cleanup efforts, your immediate task is to develop a filter that effectively removes ash and soot and reduces turbidity. Additionally, anticipate other contaminants—details on potential mystery pollutants are outlined in the Testing section. This competition challenges you to innovate for a sustainable future, providing foundational solutions for a cleaner, healthier community.

Testing

Students will be tested on the cleanliness of their filtered water using a turbidity meter. A higher turbidity (NTU) correlates to more particulates in the water, and results will be scored out of 300 NTU. Below are examples of various levels of turbidity:

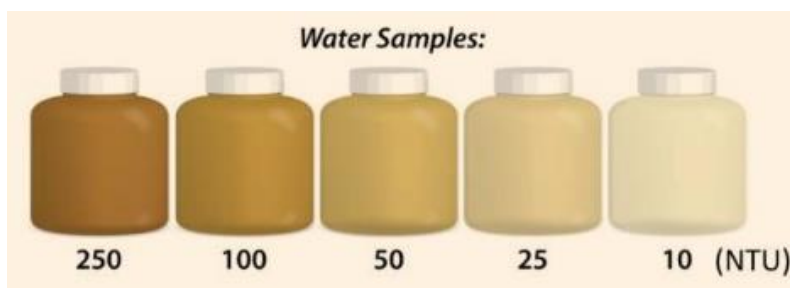

Students will also be tested on the water flow of their filter. 600 mL of water will be passed through the filter. At the **2-minute mark**, the amount of water that has passed through the filter will be scored out of 600 mL. Note that filtering out the full 600 mL is not possible, so teams should balance the effectiveness of the filter vs the water output. **Students must filter out at least 15 mL of water for testing**, or they will receive 0 points for the water output scoring section.

Along with the ash, one “mystery pollutant” will be added to the water. Some possible pollutants are plastic waste, metal particles, Styrofoam pieces, grass, or pebbles. Students will discover the identity of the “mystery pollutant” on competition day so they must prepare for any scenario beforehand. The removal of the mystery pollutant is worth 5 points and is scored as “all or nothing”.

Presentation

Student presentations should be 3-5 minutes and should:

1. Explain the importance of chemical engineering in water filtration
2. Include their filter design process and filter design blueprint
3. Show knowledge of chemical engineering concepts—adsorption, absorption, and chemical reactions
4. Show general preparedness and neatness in the presentation

Rules

- Teams must bring their verified materials.
- Teams must bring any tools or adhesives needed to assemble the filter.
- Before competition day assembly, all materials must be separate and unassembled.
- On competition day, **teams will build their filter inside a provided 2-liter Pepsi bottle**. The bottom 2 inches of the bottle will be cut off to allow for students to insert their materials.
- The filter must allow for water to be poured through from the top and be collected at the bottom.
- Students must provide a list of **ALL materials** used including any chemicals.
- Students must provide a tab of the total cost of all materials. Only account for the materials used. For example, if a pack of 50 cotton balls is bought for \$10, but only 5 cotton balls are used, the cost is \$1 (5 cotton balls / 50 cotton balls) * (\$10 total cost).

Send the material list, cost sheet, pictures of all materials, and any safety data sheets to chemical competition co-leads (see contact information section below) by **October 20th** at 11:59pm.

Certain materials will NOT be allowed. See the list below and ensure student's filter follows all restrictions. Filters violating any restrictions will not be allowed to compete. Competition co-leads reserve the right to allow or disallow materials upon verification and day-of competition.

If students have any questions regarding materials, **please reach out to competition co-leads for further clarification! We will respond promptly!** If we do not respond within 3 workdays (Monday through Friday), follow up on the email and CC hmurnberg@ku.edu.

BANNED MATERIALS:

- Premade filters or filter kits
 - Filter must be made fully from scratch
- Coffee filters
- Fabric/cloth patches or squares
- Reactive or hazardous materials (halogens, natural gas, strong acids/bases; must be safe to consume after the filtration process) **Teams MUST include a Safety Data Sheet for any chemicals used for the filter.**

Scoring

Scoring Component	Developing			Proficient	Excellent	Total
PART 1: WATER FILTER						
Removal of ash particles (Turbidity Test)	Scored out of 300 NTU—300 NTU is 0 points, 0 NTU is 50 points					___/50
Water output after 2 minutes	Scored out of 600mL— 0mL is 0 points, 600mL is 20 points					___/20
Removal of mystery pollutant	Any remaining (0)	Complete removal (5)				___/5
Filter design is cost effective	More than 40\$ (0)	\$30-\$40 (5)	\$15 - \$30 (10)	Less than \$15 (15)		___/15
Part 1 score is worth 90% of overall score						
PART 2: PRESENTATION						
Explains importance of chemical engineering in water filtration	0 - 1			2 - 3	4 - 5	___/5
Shows filter design process, material choices, and filter design blueprint	0 - 3			4 - 7	8 - 10	___/10
Shows knowledge of engineering concepts— adsorption, absorption, and chemical reactions	0 - 3			4 - 7	8 - 10	___/10
Presentation is neat and well thought out, team is prepared and knowledgeable about topics	0 - 1			2 - 3	4 - 5	___/5
Part 2 score is worth 10% of overall score						
FINAL SCORE = (Part 1 score) + (Part 2 score/30) * (10%)						

WATER FILTER SCORING EXAMPLE: If a student's filtered water had 70 NTU, filtered out 220 mL of water, removed all of the mystery pollutant, and they spent \$20 on the filter, they would receive:

- 38.33 points of out 50 for the turbidity test [$(1 - (70 \text{ NTU} / 300 \text{ NTU})) * 50 \text{ points}$]
- 7.33 points for water output [$(220 \text{ mL} / 600 \text{ mL}) * 20 \text{ points}$]
- 5 points for removal of mystery pollutant
- 10 points for cost

What To Expect Day of Competition

Students will prepare their blueprint and presentation at home and bring them to the University of Kansas. Once students arrive, an empty 2-Liter bottle with the bottom cut off will be provided for students to build their filter in. **Teams will have 30 minutes to build their filter.** They must bring all the materials they will use day-of in a separate and unassembled state. Students should also plan to bring tools they will need during the building process. Pictures of materials and cost sheets must be sent to co-leads for verification and approval by October 20th. After teams are done building, their filter will be set up and filtered with a pre-prepared solution that all teams will test with. Afterwards, they will present their filter presentation to a panel of judges.

Contact Information

If there are any questions, please reach out to the two Chemical Competition Co-Leads, Irene Xu (irene.xu@ku.edu) and Zion Bradsher (zion@ku.edu).

** If reaching out to one co-lead for a question, please CC the other co-lead as well! **

High School Design: *Civil Engineering* *Competition*

With support from



Competition Overview

Your team has just been hired by a structural engineering firm to design a skyscraper on a valuable plot of land in Tokyo. The city famously lies over an active fault line, so your building must withstand high-magnitude earthquakes. Your task is to design, build, test, and present the building to your stakeholders and explain your design choice and how it is sustainable and ready to withstand frequent and high seismic activity.

Buildings will be scored based on the amount of shake force it can withstand, how much load it can support, and the weight of the structure.

Testing

- The structure will be tested on KU's **uniaxial shake table**
- Loads will be applied to the top of your structure
 - Loads will be in increments of ½ lb
 - Loads will be made from Ziplock bags of sand
- Testing will be performed with 10 second intervals of shaking before more weight is added
- Each team gets five minutes to perform 6 tests on the shake table
 - Teams must start with ½ lb plus the plywood on the first test
 - Teams can choose between two different sizes of plywood to be set on top of their structure
 - 13"x13"
 - 18"x18"
 - Your choice of plywood size will not affect your score.
 - Teams will then decide how much weight they want to add on before their next test

- Your structure must survive the ten seconds of shaking to count that amount of weight towards your score
- Structure will be tested until failure/your structure cannot hold the plywood on top anymore, or the team agrees that the competition should be halted
- Each team will have the mass of their structure taken before testing

Presentation

The slideshow presentation will showcase your team's design decisions and how your structure is resilient to earthquakes, as well as earthquake resilience features that your building would have if fully constructed.

Students are encouraged to research designs that currently exist and find new ways to improve upon them. Overall, the presentation should convince judges why their design should be selected for potential construction by the partnering company.

Students will have 3-5 minutes to present while judges take notes. After the presentation, judges will have 2 minutes to ask questions. Judges will pull from a list of pre-determined topics curated by the Civil competition team prior to the event day.

The students will bring their posters or submit their presentations by emailing mac.key@ku.edu and kelseyschnettgoecke@ku.edu by 11:59pm on October 22nd.

Rules

- Students must come to competition day with their structure fully built
- Be as creative as you want on your design
- Total **height** range: min 50"- max 56"
- Total **width** range: min 13"- max 17"
- Total **length** range: min 13" - max 17"
- Your structure must have a flat base and top to be taped onto the shake table with masking tape
- MUST ONLY use 1/4-inch balsa wood sticks and hot glue for entire structure
- MUST have a **flat AND level** top and bottom with the dimensions outlined above
- The balsa wood cannot be glued together parallel to each other for more than 1 inch. ½ inch of leeway will be given
- Must be an open frame design without any fully enclosed sides of the structure

Scoring

- Each half a pound will equal five points. ½ lb = 5 points
- The point system is cumulative. For each successful test, points will be added to the total score
- Your presentation score will be added to your testing score after testing
- In a tie in overall scores, the team with the smallest mass will win.

Presentation Rubric:

	Beginner 1 point	Developing 2 points	Acceptable 3 points	Effective 4 points	Excellent 5 points
Walk through of team's design process and early ideas	Failed to address prompt or only explained one part of the prompt	Slightly addressed early design options	Addressed some portion of their design choices with vague explanations	Addressed all effectively and with some level of detail	Full detail and explanation behind early structural ideas
Current existing structures students took inspiration from	Failed to address any current structures that specialize in reducing seismic effects	Slightly touch on existing structures	Addressed the prompt with broad details	Addressed the prompt by highlighting at least two existing designs	Gave a fully detailed explanation on three current effective structural designs
Explanation of final structures design	Fails to address the final structures design	Hardly touches on the team's final design	Addresses the final design with broad detail	Goes into detail about final design and ties in why they chose their design	Effectively goes over the final design and makes several points highlighting important components of the design
Overall effectiveness to pitch groups structural design	Does not pitch design for building at all	Gets some points across but fails to really sell the judges	Pitches their design with broad explanations	Pitches the structural design well with good points	Group presents an extremely persuading design with confidence as to why their design is superior
Proposed earthquake resilience features for hypothetical real-life construction.	Failed to address any earthquake resilience features in their presentation.	Mentioned weather earthquake features but did not expand or explain the effectiveness of them.	Addressed 1 feature that contributes to the overall building design.	Addressed 2 features that contribute to the overall building design .	Addressed 2 or more features that contribute to the overall building design with proposed improvement of industry practices.

What To Expect Day of Competition

On the day of the competition, teams will bring their buildings to the event testing room. Teams should have their presentation ready to present to the judges during their assigned time slot. Testing will occur before or after the presentation depending on the assigned time. Refer to the Code of Conduct for the HSD Tardiness Policy. We will provide extra balsa wood and glue in case of emergency.

Contact Information

If any questions arise, please email both Civil Competition leads, Mac Key (mac.key@ku.edu) and Kelsey Schnettgoecke (kelseyschnettgoecke@ku.edu)

High School Design: **Computer Science Competition**

With support from



Competition Overview

You just moved to a new city where you have been hired by a sustainable energy company to analyze and present weather data to promote sustainable energy choices. The company has been gathering data, and they want a summary of their findings. The company wants you to create an application that allows them to query different weather points that they have collected and return summary statistics. Your challenge is to design an application and present it to your stakeholders, including information on how you designed the application and how it works.

On competition day, students will present their applications, discuss their knowledge of the code they wrote, explain design choices, and more.

Problem Statement

Develop an interactive app designed to process weather data from an input file and present it through a user interface. Detailed instructions on weather data and processing, along with input file specifications, are outlined in Project Requirements. In addition, to earn bonus points, teams may attempt to implement any number of the challenge features given in Extra Features. This should be completed before competition day.

On competition day, teams will participate in an on-site challenge to add an additional mystery feature to their application. After the challenge, teams will demonstrate their application and its functionality to a panel of guest judges, who will score the teams according to the rubric outlined in “Project Demonstration and Scoring.”

Project Requirements

The software created should include the following functionality:

A user interface that allows the user to request data.

- Users must be able to specify the input file interactively.
 - Ex: Supply via the command line or by text prompt in the terminal
- Users will describe what data they want to see.
 - Functions may include minimum, maximum, average, and single point.
 - Ex: “Max of temperature_max from day 0 to day 6”
 - The standard query format includes day indices as shown in this example.
 - Ex: “Max of wind_speed_max from 2024-03-28 to 2024-04-01”
 - The standard query format includes date indexes as shown in this example.
 - Ex: “What is the weather_code on 2024-03-28”
 - Ex: “What is the precipitation_sum on day 5”
- Natural language processing is not required for this project, such that the program may also use other interactive features of input. If the user can query through the standard query format by specifying date ranges and data points, the user interface is considered functional.

A way to parse the data in the input file, with support for the following file structure:

- Each line has a **data point** followed by a colon (:), and a space-delimited list of values.
 - Ex: “temperature_max: 20 30 50\n”
- Assume imperial metrics, such as Fahrenheit, miles per hour, and inches.
- An example file is provided below in “weatherdata.txt”.
- weather_code is a WMO code that represents the weather for that day. For instance, 61 wmo means “slight rain showers.” These codes are found below, taken from the [Open-Meteo](https://www.open-meteo.com/en/docs/api/parameters#weather) API documentation. A more standardized chart can be found at <https://www.nodc.noaa.gov/archive/arc0021/0002199/1.1/data/0-data/HTML/WMO-CODE/WMO4677.HTM>.
 - 0 Clear sky
 - 1, 2, 3 Mainly clear, partly cloudy, and overcast
 - 45, 48 Fog and depositing rime fog
 - 51, 53, 55 Drizzle: Light, moderate, and dense intensity
 - 56, 57 Freezing Drizzle: Light and dense intensity
 - 61, 63, 65 Rain: Slight, moderate, and heavy intensity
 - 66, 67: Freezing Rain: Light and heavy intensity
 - 71, 73, 75 Snow fall: Slight, moderate, and heavy intensity
 - 77 Snow grains
 - 80, 81, 82 Rain showers: Slight, moderate, and violent
 - 85, 86 Snow showers: Slight and heavy
 - 95 Thunderstorm: Slight or moderate
 - 96, 99 Thunderstorm with slight and heavy hail

Example File: weatherdata.txt

```
date: 2024-04-24 2024-04-25 2024-04-26 2024-04-27 2024-04-28 2024-04-29
weather_code: 3.0 61.0 3.0 55.0 3.0 63.0
temperature_max: 54.9464 52.6064 61.9664 52.2464 52.6064 48.4664
temperature_min: 44.2364 47.1164 48.6464 47.9264 42.796402 40.0064
precipitation_sum: 0.0 0.22440945 0.0 0.1456693 0.0 0.2952756
wind_speed_max: 9.309791 10.116089 8.249648 10.711936 13.588738 7.4495792
precipitation_probability_max: 45.0 100.0 100.0 100.0 97.0 100.0
```

Extra Features

Bonus points will be awarded to students who implement the features described below. It is encouraged to try these, but not expected that many groups complete all the extra credit.

- (Small: **4 points**) Create a connection to an online weather API and compare data against the input file.
 - The comparison will be a function of data point, timeframe, and location. The judges will give a location latitude and longitude, timeframe, and data point(s) for the application to make a request.
 - Ex: “Compare the wind_speed_max on 2024-04-24 at latitude x and longitude y”
 - Output may be akin to: “In the given data, the wind_speed_max was 9.31 mph while at latitude x and longitude y it was 5.40 mph.”
 - Ex: “Compare the maximum temperature_max for days 0 through 5 with latitude x and longitude y.”
 - Output may be akin to: “The maximum temperature_max for days 0 through 5 was 61.97 degrees Fahrenheit, which is less than the max of 82.34 degrees Fahrenheit at latitude x and longitude y.”
- (Medium: **8 points**) Create a histogram of a given data point.
 - Ex: “Create a histogram of wind_speed_max between day 0 and day 4”.
 - The histogram will be a function of data point and timeframe.
 - Output formats are ambiguous but must be visual. An image is sufficient, but other interfaces such as a terminal or browser are also acceptable.
- (Large: **15 points**) Make your application usable through a representational state transfer application programming interface (REST API) using Hypertext Transfer Protocol (HTTP) requests. Specifically, the following functionality should be implemented:
 - GET requests should be used to view given weather data as a function of data point(s) and timeframe.
 - POST requests should be used to add new dates of data. This should include all data points provided in the input file, including date.
 - PUT requests should be used to edit data details. This should take a date, data point, and value, and change the associated value accordingly.

- DELETE requests should be used to remove specified dates (and their associated data points) from the stored data.

All data returned by the API should be serialized using JavaScript Object Notation (JSON).

Onsite Challenge

In addition to the features detailed in the Project Requirements, a mystery feature that teams' software should include will be announced on High School Design Day. Two hours before the team's project presentation, students will receive an email disclosing the mystery feature. There will be a designated room on competition day where teams will work on implementing the mystery feature.

No resources will be provided besides access to KU's guest Wi-Fi. If you are relying on remote resources (e.g. servers in the cloud) it is not guaranteed that teams can access these during competition day. Students using school computers must make sure that they can access other public Wi-Fi networks if internet access is required to work on the project.

Project Demonstration & Scoring

After completing the on-site challenge, teams will present their source code and demonstrate its functionality. This demonstration should display all the required features of the product detailed in Project Requirements, as well as the implementation of the mystery feature introduced in the on-site challenge, alongside any challenge features.

Teams will use their own devices to demonstrate their software. Presenting off a laptop or other handheld devices is acceptable, given that the app and source code can be demonstrated on said device. If you are unable to demonstrate using your device, please contact Dylan Kneidel (dckneidel@ku.edu).

Laptop chargers will not be provided, and power outlets will not be available outside of the hackathon room. It is the team's responsibility to ensure their devices are properly charged for their demonstration.

After the demonstration, a Q&A session will follow that is moderated by a guest judge panel. Judges will have the opportunity to ask questions they have about the project, and in addition to project-related questions, the judges will ask the team to do the following:

1. To show the source code for a chosen feature of their app and walk through how that code works. The feature choice will be revealed after the demonstration of the project.
2. Judges will give teams several test cases for them to run on their app.

Teams will be scored on their demonstrations and answers to questions by the rubric below.

Criterion	Outstanding	Exemplary	Satisfactory	Needs Work
Initial Requirements	Project addresses all initial requirements in a creative and user-friendly fashion. (25 pts)	Project addresses all the initial requirements. (20 pts)	Project addresses two of the initial requirements. (15 pts)	Project only addresses one or more of the initial requirements. (10 pts)
Source Code Understanding	Code is self-documenting and well-organized. The team can fully explain all parts of the logic of the feature. (20 pts)	The team can fully explain all parts of the logic of the feature. (15 pts)	The team can partially explain the logic of the feature. (10 pts)	The team cannot explain any of the feature logic. (0 pts)
Mystery Feature (introduced during on-site challenge)	The team fully implements the mystery feature with no bugs. (9 pts)	The team fully implements the mystery feature, but bugs are present. (7 pts)	The team partially implements the mystery feature. (5 pts)	The team fails to implement any portion of the mystery feature. (3 pts)
Project Demonstration	All test cases function as expected. (20 pts)	Two-thirds of test cases function as expected. (15 pts)	One-third of test cases function as expected. (10 pts)	Less than one-third of test cases function as expected. (5 pts)
Q&A	The team can fully answer all the judges' questions. All team members contribute to answers. (15 pts)	The team can fully answer all questions, but not all team members contribute to answers. (10 pts)	The team can partially answer all the judges' questions. (7 pts)	The team is only able to answer some of the judges' questions. (3 pts)
Presentation Skills	The team presents their product with enthusiasm in an easy-to-understand manner. All team members are active participants in the demonstration. (5 pts)	The team clearly presents their product but lacks enthusiasm. All team members are active participants in the demonstration. (4 pts)	The team clearly presents their product, but not all team members actively participate. (3 pts)	The presentation of the product is unclear and difficult to follow. (1 pt)

Judges will be able to award partial credit outside of the point categories in the given rubric, with the team with the highest score deemed the winner. Each judge will fill out a rubric, with their averaged scores giving the team's final score before bonus points. Afterward, bonus points will be awarded for each challenge feature implemented by the

team. In the event of a tie, design aesthetics (i.e. creativity, consistency, and cleanliness in choice of colors, fonts, etc.) will be used to break the tie.

Plagiarism

Cheating will not be tolerated in any form. Cheating includes, but is not limited to, the following:

- Using open-source code and claiming it as your own.
- Using AI-generated code and claiming it as your own.
- Having an individual outside of your team makes major contributions to your project's codebase.
- Recycling code from a previous project.

If a team is caught cheating, it will result in immediate disqualification from the competition.

If you have any questions or concerns, please contact:

- A. Srihari Meyoor (smmeyoor@gmail.com)
- B. Dylan Kneidel (dckneidel@ku.edu)

High School Design: *Mechanical Engineering* *Competition*

With support from



Competition Overview

A tornado has just touched down near KU and your team's tornado chaser is racing to get to the eye of the storm! In this competition, a target (representing the tornado) will be marked on the ground some distance away from the starting line. Your challenge is to construct a vehicle *and* ramp such that the vehicle travels and stops as close to the target as possible. Teams closest to the target will perform the best, but be careful, as the exact distance of the tornado will not be known until competition day!

Testing

Testing of devices will occur at the KU campus. Teams will be given one run to go a qualifying distance of at least 3 meters, then two runs to stop as close as possible to a designated point (the better score from these two runs will be used in scoring). **The goal of the competition is to receive as few points as possible.** If teams exceed the qualifying 3-meter distance, they will receive 100 points and if not, 300 points. See Scoring below for more information about how points will be allotted. The testing of the chaser (vehicle) will be conducted on a hard, low friction floor akin to indoor concrete. There will be 10 minutes total for teams to run, **including the qualifying run.** Only runs conducted before the 10 minutes are up will be counted, but only a max of 3 runs (one qualifying and two targeted) can be completed, regardless of time remaining. Participants can spend the time conducting their runs and making modifications to the chaser between runs as they see fit. Modifications may *not* be made to the ramp, and the front edge of the ramp must *stay flush with the start line* for each run. Between chaser modifications, the chaser will be checked to make sure the device is within the stated parameters (see Competition Rules below). This check will not cut into the allotted 10 minutes. The designated tornado distance will be specified on the day of the competition and will be between 1 and 3 meters from the

start line. The distance will be the same for both post-qualifying runs and for all contestants.

The following steps must be completed to complete a successful test:

1. The chaser and ramp will begin behind the start line. The front edge of the ramp must be flush with the start line.
2. When the tornado siren sounds, the team will release their vehicle.
3. After the chaser stops moving it will be scored based on the judging parameters (see Judging below). The run can be disqualified if it breaks one of the rules (see Competition Rules below).
4. If the chaser starts before the tornado siren sounds, or if the distance cannot be measured (participants move vehicle before it can be measured by competition leads), this will be considered a failed run.

Presentation

After testing, team members must be prepared to present components of their project and explain the function of each, demonstrating an understanding of their device and the related engineering concepts. A budget breakdown is a required portion of the presentation. Presentations should be practiced beforehand and less than 5 minutes in length. Teams are encouraged to make a visual presentation such as a slideshow. Teams should be prepared to answer a few questions about design choices at the end of the presentation.

Rules

- Teams may only bring one chaser and one ramp.
- The chaser competition will contain these elements: The car frame, which may contain a braking system, and a ramp.
- The storm chaser (vehicle) should not exceed a weight of 2kg, and the chaser and ramp together must be able to fit in a box that has a 60cmx60cm base and is 100cm vertically.
- The qualifying distance will be 3 meters. If the car reaches or exceeds this range, the team will be allotted 100 points, and if they do not reach this range, they will be allotted 300 points (lower score is better). Teams will have **one** attempt to meet the qualifying distance.
- The target point (tornado) will be directly in front of the start line, 1m-3m away from it. Teams will be told the exact distance on the day of HSD. The challenge will be to achieve the best accuracy to that distance. Teams may orient their ramp however they see fit as long the entire ramp is behind the start line and the front edge is flush with the start line.
- The chaser will have **1** attempt to meet the qualifying distance, and **2** attempts to accurately reach the designated tornado point within the time limit.
- When the tornado siren sounds the chaser must be released from the ramp. Teams cannot push the chaser forward or accelerate in any way other than with gravity. After release, the chaser may not be touched until after the run is complete and measured.

The chaser and braking system must operate independently from the team to count as a completed run.

- All parts of the chaser must move together as one and bindings/tethers are not allowed to connect the chaser and ramp to act as a braking system.
 - Anchors are not an acceptable form of braking system.
- The chaser must stay intact and must maintain a point of contact on the ground during each run or the run will be disqualified.
- The ramp must be freestanding within the specified dimensions, remain behind the start line, and its front edge must be flush with the start line for the entire run. The ramp may not provide any additional acceleration outside of the potential energy it provides.
 - All propulsive energy must come from the gravitational potential energy of the mass of the chaser.
- Electronic components/electric devices or any form of explosive Kinetic Energy are not allowed.
 - Ex: Electronic braking systems, CO2 canisters, and combustion engines
- For safety reasons, teams must make sure that their cars do not contain any parts that could be released in an unexpected or unsafe manner (**No springs are allowed**).
- The car frame and ramp must be homemade and not be a part of a kit.
- No 3D printing or other forms of additive manufacturing (resin printer) is permitted.
- There should be a marking on the center of the front face of the chaser for measuring purposes.
- Modifications to the original chaser can be made between rounds, **but no modifications may be made to the ramp**.
- Your chaser and ramp must not exceed a total cost of \$30.
 - This is the final cost of the chaser. If you purchase a material that is \$30, but only use half of that material, you can say that it was \$15. The final cost does not include prototyping or any other testing costs. If miscellaneous materials are used, estimate the cost of those materials. However, adhesives do not need to be included in the final cost calculation (tapes and glues).

Diagrams/Schematics

Example of a competition storm chaser - The blue circle exemplifies the marker on the front of the car.

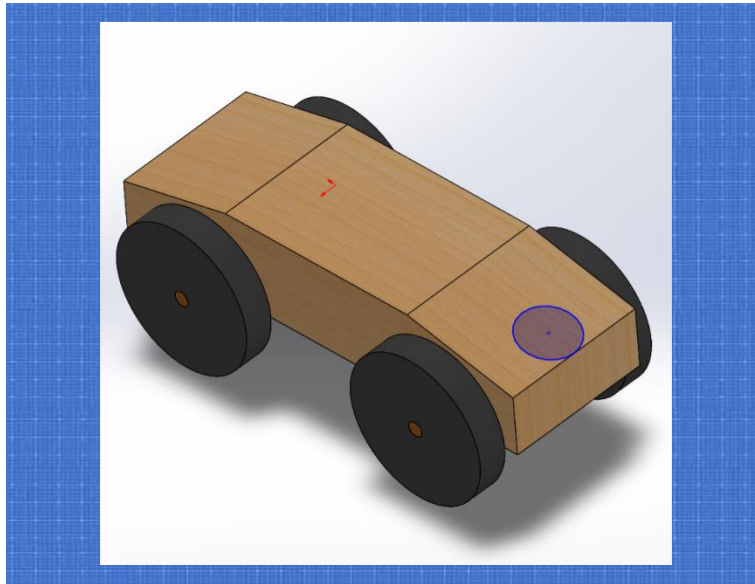

Scoring

Chaser Score: Points will be given based off the accuracy of the chaser with any rule violations.

1. Q = 100 points if the chaser meets the qualifying distance, and 300 points if the chaser does not meet the qualifying distance
2. D = Distance from the marker on the front face of the chaser to the tornado (centimeters)
 - o The distance from the front middle to the tornado will be measured in centimeters and recorded as distance, D.
3. P = Each violation of the rules stated above will result in an additional 100pts to be added only to the run in which the penalty occurred

Presentation Score: (8 Points)

Presentation Rubric

Topic Covered	Points and Criteria		
Budget	2 Points- Budget is present and described through each component used.	1 Points- Budget is present but not described very clearly.	0 Points- No budget present.
Engineering Design Elements Used	2 Points- The team shows how they used engineering design to build the best chaser possible.	1 Point- Little explanation on how the team went about solving the problem given.	0 Points-There is no mention of the engineering design elements the team used.
Lessons Learned	2 Points- prototypes and previous models are shown	1 Point-The lessons the team learned is	0 Points- There is no mention of the lessons

	for how they taught the team to create a better design.	mentioned but not explained	learned through this project
Preparedness and presentation skills	2 Points- Presentation is well prepared and under 5 minutes	1 Point- Presentation was not practiced and could have been structured better.	0 Points-Little to no preparation and poor presentation skills.

Final Score Addition:

Final Score (Max is 1,000 points) = the best run score (lowest point value).

Lowest score wins.

- Run score= Q+ D + P – 0.025*Presentation Score.

What To Expect Day of Competition

On the day of the competition, teams should bring their chaser and ramp to the event testing room. They should also bring any necessary materials for any modifications they might want to perform to the chaser. Teams should also have their presentation ready to present to the judges during their assigned timeslot. Each team will be assigned a 10min slot for their chaser testing and a 10min slot for their presentation. If teams do not show up for their timeslots they will be disqualified from the competition. A list of what materials to bring on competition day:

- Your chaser and ramp
- Your presentation
- The total bill of materials/itemized project budget
- Any materials needed for chaser repairs.

Contact Information

Competition leads (Irmischer and Thompson) have the final say on all rules. Please reach out with any questions regarding the competition and/or rules.

Irmischeram@ku.edu Claire.thompson@ku.edu